



GREY FOX CONCEPTS

1/35 Australian M113
Sponson Armour
SKU: GFC350013

Description: Australian M113 Sponson Armour for one M113 vehicle.

History: During the Vietnam conflict, the Australian M113s were fitted with sponson armour on each side of the vehicle, to help counter the threat of mines and IEDs. This modification occurred from 1969 onwards. All M113 in Australian service were fitted with this armour. M113 FSV hulls that had their turrets removed and sent to New Zealand Army also had this armour fitted to them.

Parts: One set of Sponson Armour for an M113 vehicle. This update/correction kit is suited to the AFV Club, M113A1 ACAV AF35113, and their M113A1 APC AF35291.

Safety: This is a 3D printed resin product. When working with this product, take the precautions to prevent inhalation of the dust produce by cutting, sanding or filing. Wearing a dust mask and eye protection while working on the product. Work in a well-ventilated area.

Instructions:

For the M113A1 ACAV AF35113. This kit does not come with sponson armour.

1. Remove GFC kit part from the supports and lightly sand that edge.
2. Step 1 of the kit's instructions. Remove the raised protrusion on each side of the sponson, as in the Figure 1.
3. Dry fit the parts, by placing the front edge of the sponson appropriately 1mm back from the vertical weld on the kit as per Figure 2 on each side. The sponson armour should overhang .5mm from the hull of the kit. Attached with CA glue.

For the M113A1 APC AF35291

1. Remove GFC kit part from the supports and lightly sand that edge.
2. Step 1 of the kit's instructions. No not add part L16. Remove the raised protrusion on each side of the sponson, as in the Figure 1.
3. Dry fit the parts, by placing the front edge of the sponson appropriately 1mm back from the vertical weld on the kit as per Figure 2 on each side. The sponson armour should overhang .5mm from the hull of the kit. Attached with CA glue.

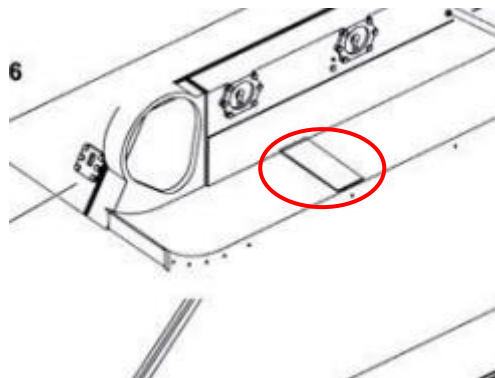

Figure: 1

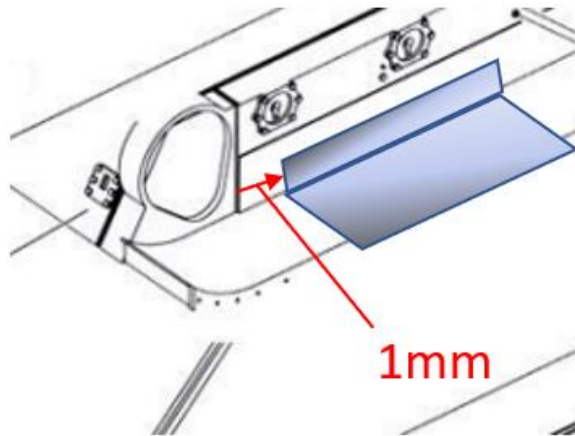

Figure 2